

Holzworth HA7062D PHASE NOISE ANALYZER

20GHz / 50GHz¹ REAL TIME 0.1Hz - 100MHz Measurement Offsets

The HA7062D carries the same ANSI Z540 calibrated accuracy as its predecessors; as well as industry leading data acquisition speeds, ease of use, and extremely high reliability. The additional features that come with HA7062D include: an expanded measurement offset range of up to 100MHz, input splitter bypass ports for higher channel-channel isolation, independent baseband input ports and AM measurements with crucial AM immunity for the PM signal.



REAL TIME CROSS CORRELATION COVERING 10MHz to 20GHz / 50GHz¹

ELIMINATION OF CROSS-SPECTRUM COLLAPSE FROM AM NOISE

HA7062D AM/PM cross check eliminates data irregularities. Holzworth's latest real time cross correlation architecture offers simultaneous AM/PM measurements. This unique feature was integrated to eliminate cross-spectrum collapse which is now a proven phenomena causing false high/low measurements, nulling, and artificial bumps in the phase noise (PM) data.

ANSI Z540 CALIBRATION

Measurement accuracy of phase noise test data is a common concern. All Holzworth analyzers come with a NIST traceable calibration covering down to 0.1Hz offsets. The ANSI z540 calibration standard is a mandatory procedure for Holzworth phase noise analysis products because phase noise data that is not traceable to an industry standard is open to speculation.

INTUITIVE INTERFACE

Holzworth Instrumentation has been measuring the phase noise of 100% of its own shipped products since the company was founded in 2004. There is an understanding that the user interface is as important as the capabilities of the actual hardware.

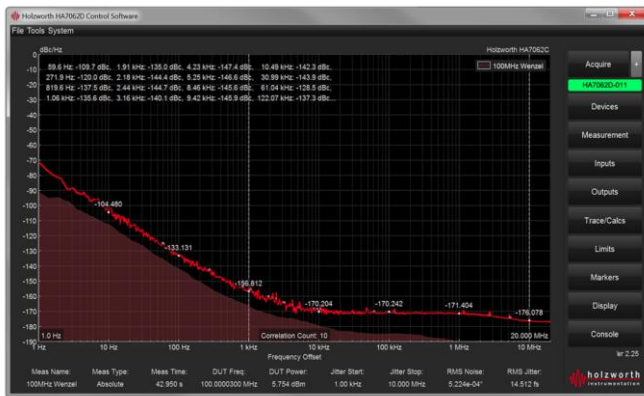

The highly intuitive and feature rich HA7062D interface is a driver-free GUI that operates on any standard PC.

Originally targeted for use in high throughput manufacturing, the HA7000 Series has been optimized for accurate measurement speed while offering the flexibility to be controlled via LABVIEW™, pure command line or any other programmable interface.



UNIQUE ARCHITECTURE

The HA7062D real time phase noise analyzer has been designed with a reconfigurable front end that allows for a high level of user flexibility while setting up both standard and unique measurement scenarios. The HA7000 Series are the industry's only phase noise analyzers that allow the user to measure the actual measurement noise floors of the instrument vs. making theoretical approximations.

INTERNAL / EXTERNAL LO MODE

The HA7062D leverages a pair of internal Holzworth HSX Series RF synthesizers for optimal LO generation, which are also accessible at the front panel. For the lowest possible measurement floors, users can apply external, fixed frequency LOs to the automated test system.

DIRECT BASEBAND INPUTS

The only phase noise analyzer available on the market that allows for cross correlation of baseband signals. DC coupled, baseband inputs allow for a variety of measurements including power supply noise.

INPUT SPLITTER BYPASS

Another Holzworth exclusive. The splitter bypass allows for a variety of measurement configurations including the unique ability to actually measure the noise floor limit for any given frequency.

RESIDUAL PHASE NOISE

The HA7062D also offers fully automated additive measurement capability for multi-port devices, including mixers and DDS circuits; while maintaining the ANSI z540 traceability.

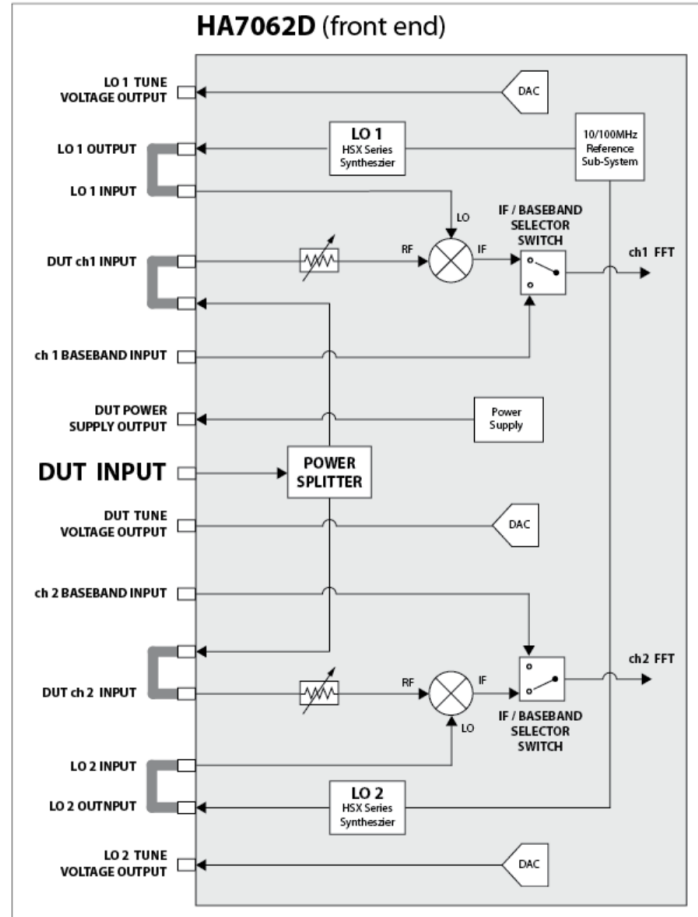

PERFORMANCE SUMMARY

¹ DUT Tuning Range	10MHz to 20GHz (50GHz with Part No. HA7063A)
Measurement Floor	< -195dBc/Hz (as measured)
Measurement Speed (per correlation)	<1s (100Hz-100MHz), <5s (10Hz-100MHz)
Measurement Offset	0.1Hz to 100MHz (z540.1 calibrated)
Measurement Types	Absolute, Residual, AM, Baseband, Jitter, Spurious
Warranty	3 years