



Stirrer M

STIRRER FOR REVERBERATION CHAMBERS MODEL M

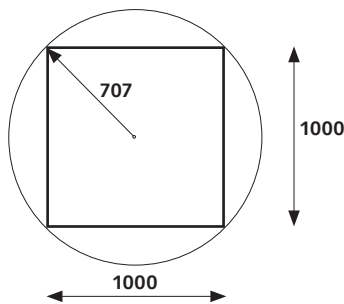

Figure 1

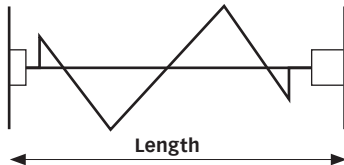

Figure 2

Technical specifications

Stirrer (see figure 1)

Radius during rotation:	approx. 707 mm
Length:	approx. 2610 mm
Edge length:	approx. 1000 mm

Stirrer mounted in vertical position (see figure 2)

Max. length (motor+stirrer+counter bearing):	approx. 3500 mm
Min. length (motor+stirrer+counter bearing):	approx. 3000 mm
Position of the motor:	mounted on chamber ceiling
Other dimensions on request.	

Stirrer mounted in horizontal position (see figure 2)

Max. length (motor+stirrer+counter bearing):	approx. 3500 mm
Min. length (motor+stirrer+counter bearing):	approx. 3250 mm
Position of the motor:	mounted on chamber wall
Other dimensions on request.	

Motor

Stepping motor for high-precision angle setting	
For tuned and stirred mode	
Specified up to minimum 600 V/m continuous field strength	
Motor installed within the chamber (no influences on screening effectiveness of the room by stirrer motor shaft feed through)	
Positioning accuracy:	+/-0.5°
Angle resolution better:	0.1°
Min. speed:	0.5 turn/minute
Max. speed:	6 turns/minute
Dimension (L x W x H in mm):	350 x 272 x 250

Filter

Typical attenuation 100 MHz to 1 GHz:	>100 dB
Typical attenuation 1 GHz to 10 GHz:	>100 dB
Typical attenuation 10 GHz to 18 GHz:	>80 dB
Dimension (L x W x H in mm):	210 x 130 x 53
Feed through:	∅ 21 mm

Motor control unit (mounted outside the chamber)

Cable length between motor and control unit:	max. 10 m
Dimension (L x W x H in mm):	300 x 300 x 205
Supply:	110 to 230 V, 50 or 60 Hz



Stirrer M STIRRER FOR REVERBERATION CHAMBERS MODEL M

Technical specifications (continued)

Power switch:	hardware switch
Communication interface to USO 4013:	opt. RS232
Connection:	2x HFBR0501 socket for 1 mm fiber optic cable
Distance:	10 m (>10 m on request)

Environment conditions

Classification:	Indoor use only
Operating temperature:	+5 °C to +40 °C
Relative humidity:	up to 80% (no moisture condensation)

System overview

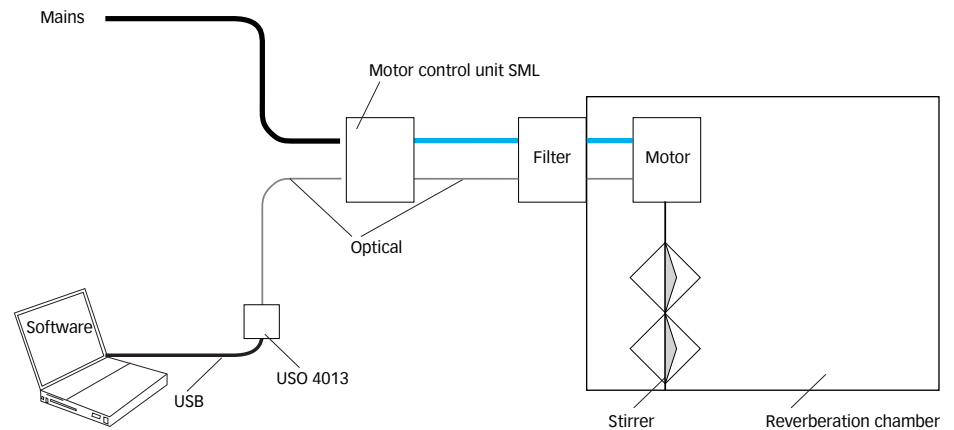

Model No. and options

253351

RC Stirrer M
Stirrer size M, remote controlled, incl. gear motor for step-wise and continuous rotation, positioning accuracy +/- 0.5°, smallest step 0.1°, motor installed inside chamber, the motor is installed inside the chamber, specified up to 600 V/m, incl. EMC filter, cables and stirrer control unit with remote interface and driver for C5I software